

**Nanotech**<sup>®</sup>

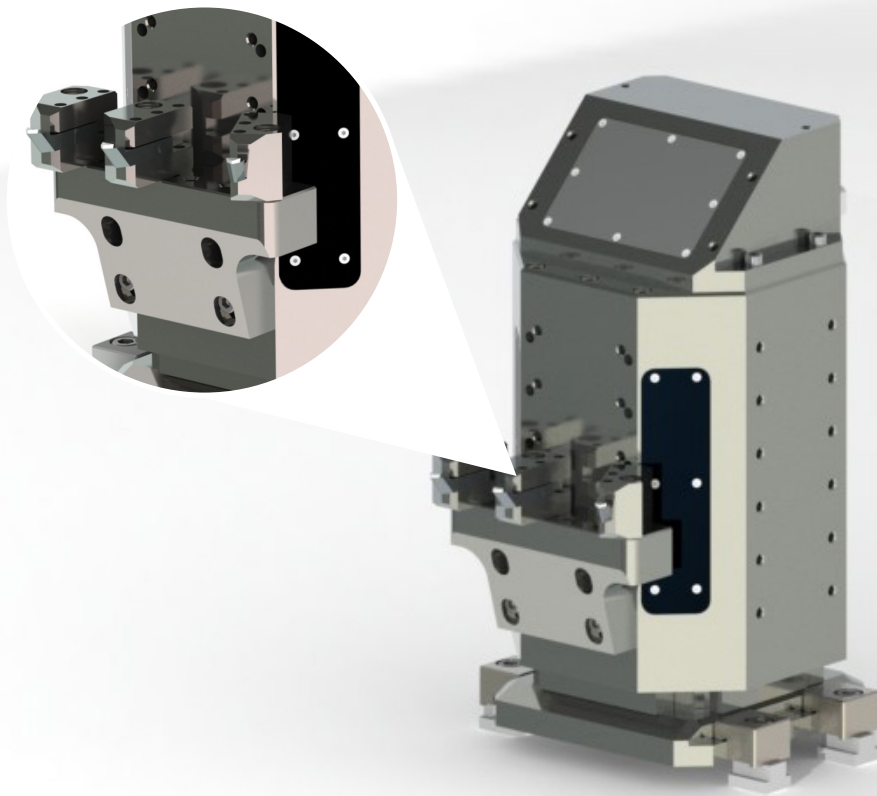

**CNC MULTI-TOOL  
HOLDER**



## Specifications and Features

VERTICAL TRAVEL	25 mm
TOTAL SYSTEM WEIGHT	50 lbs
MAXIMUM WORK LOAD	25 lbs
MAXIMUM SPEED	2000 mm/min
BI-DIRECTIONAL REPEATABILITY	XXX $\mu$ m
LINEAR RESOLUTION	0.1 nm (interpolated)

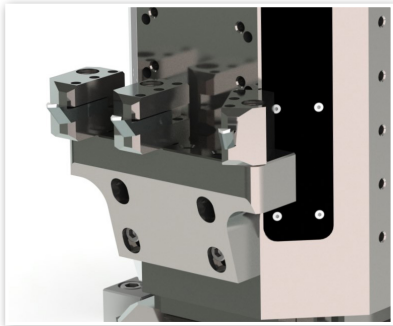

- Capable of holding up to 3 diamond tools
- Center mounted linear scale maximizes stability
- Optional side mounting of WECS & Touch Probe
- Linear motor drive with air bearing counterbalance
- Crossed roller bearing

**Nanotech<sup>®</sup>**

**Headquarters:**

Moore Nanotechnology Systems, LLC  
230 Old Homestead Hwy.  
Swanzey, NH 03446

Phone: (603) 352-3030  
Facsimile: (603) 352-3363  
Email: [sales@nanotechsys.com](mailto:sales@nanotechsys.com)

**[www.nanotechsys.com](http://www.nanotechsys.com)**

a PMT Group Company